

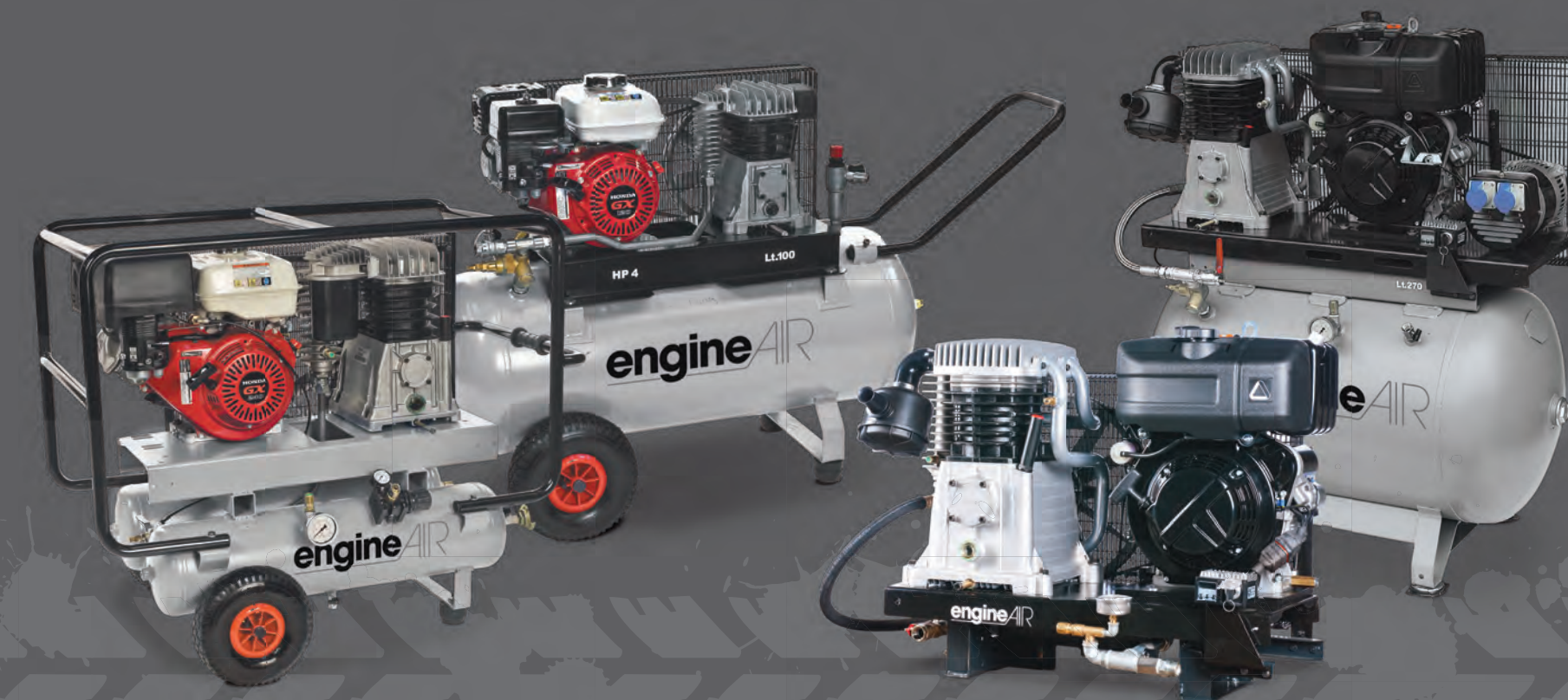

Description	Model	Vessel ltr	Pressure			Air Displacement		Engine			Sound Power LwA dB(A)	Sound pressure 4 mt. dB(A)	Weight kg	Dimensions
			bar	psi	l/min	cfm	hp	kW	Type					
engineAIR 4/100 Petrol	Mobile	100	10	145	300	11	3,5	2,6	GX120 QX9	95,7	75,7	71	1090x420x1030	
engineAIR 5/50 Petrol	Mobile	50	10	145	330	12	4,8	3,6	GX160 QX9	95,8	75,8	73	1000x410x870	
engineAIR 5/100 Petrol	Mobile	100	10	145	330	12	4,8	3,6	GX160 QX9	95,8	75,8	94	1090x420x1030	
engineAIR 5/200 Petrol	Mobile	200	10	145	330	12	4,8	3,6	GX160 QX9	95,8	75,8	120	1500x450x1100	
engineAIR 5/11+11 Petrol	Mobile	11+11	10	145	330	12	4,8	3,6	GX160 QX9	95,8	75,8	70	1070x770x1040	
engineAIR 5/11+11R Petrol	Rollbar	11+11	10	145	330	12	4,8	3,6	GX160 QX9	95,8	75,8	70	1070x770x1040	
engineAIR 7/25+25R Petrol	Rollbar	25+25	10	145	670	24	7,1	5,3	GX240 QX B7	95,9	75,9	143	1235x835x1100	
engineAIR 7/270 Petrol	Stationary	270	14	203	620	22	7,1	5,3	GX240 QX E4	103,7	83,7	223	1395x745x1500	
engineAIR 11/270 Petrol	Stationary	270	14	203	750	27	10,7	8,2	GX340 QX E4	104,4	84,4	235	1395x745x1500	
engineAIR 7/270 Diesel	Stationary	270	14	203	750	27	6,8	5,0	15LD 315	110,2	90,2	239	1395x745x1500	
engineAIR 11/270 Diesel	Stationary	270	14	203	1170	41	10,9	8,2	15LD 440	109,8	89,8	258	1395x745x1500	
BI engineAIR 8/270 Diesel 2,2kVA	Stationary	270	14	203	390	14	7,5	5,5	15LD 350	110,2	90,2	265	1395x745x1500	
BI engineAIR 11/270 Diesel 2,2kVA	Stationary	270	14	203	540	19	10,9	8,2	15LD 440	109,8	89,8	270	1395x745x1500	
engineAIR 4 Petrol	BM	0	10	145	300	11	3,5	2,6	GX120 QX9	95,7	75,7	57	860 x 490 x 750	
engineAIR 5 Petrol	BM	0	10	145	330	12	4,8	3,6	GX160 QX9	95,8	75,8	63	860 x 490 x 750	
engineAIR 7 Petrol	BM	0	14	203	620	22	7,1	5,3	GX240 QX E4	103,7	83,7	117	1200 x 685 x 880	
engineAIR 11 Petrol	BM	0	14	203	750	27	10,7	8,2	GX340 QX E4	104,4	84,4	128	1200 x 685 x 880	
engineAIR 12 Petrol	BM	0	11	160	1153	41	11,7	8,8	GX390 QX E4	104,4	84,4	142	1200 x 685 x 880	
engineAIR 7 Diesel	BM	0	14	203	750	27	6,8	5,0	15LD 315	110,2	90,2	142	1200 x 685 x 880	
engineAIR 11 Diesel	BM	0	14	203	1170	41	10,9	8,2	15 LD 440	109,8	89,8	151	1200 x 685 x 880	
engineAIR 12 Diesel	BM	0	11	160	1195	42	12	8,8	15 LD 500	109,8	89,8	154	1200 x 685 x 880	
BI engineAIR 8 Diesel 2,2kVA	BM	0	14	203	390	14	7,5	5,5	15LD 350	110,2	90,2	157	1200 x 685 x 880	
BI engineAIR 11 Diesel 2,2kVA	BM	0	14	203	540	19	10,9	8,2	15LD 440	109,8	89,8	184	1200 x 685 x 880	
BI engineAIR 12 Diesel 3kVA	BM	0	11	160	1195	42	12	8,8	15 LD 500	109,8	89,8	201	1200 x 685 x 880	

# engineAIR

## The unplugged generation



Your Authorized Distributor

# engineAIR

Petrol and diesel engine driven piston compressors  
for your remote applications

Pictures used in this leaflet are indicative and not contractually binding.

© 2012, EngineAir. All rights reserved. All mentioned brands, product names, company names, trademarks and service marks are the properties of their respective owners. Our products are constantly being developed and improved. We thus reserve the right to modify product specifications without prior notice.

## Versatile engine compressors for remote applications

The freedom to do what you want, when you want, wherever you want. To be independent under all circumstances. Who wouldn't like that? As a small building contractor or a larger construction company, if you are in harvesting business or a farmer; this is your tool.

You'll be excited about this: a range of unplugged diesel and petrol engine belt driven compressors that are easy to move, that can cope with different air demands, that can power multiple tools at the same time and simultaneously provide a steady air flow; the BlengineAIR range comprises a two-in-one solution that can provide you with both air and electricity in remote locations.

With these versatile engine compressors you are totally independent from energy sources, giving you total availability of compressed air in all circumstances. Giving you total freedom.

**engine**AIR



## Petrol Engine

Supersilenced version  
Worldwide service support

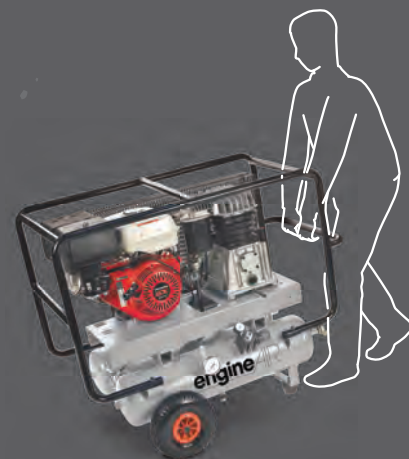

### Metal Rollbar

Offers full protection.  
Easy to carry, easy to move

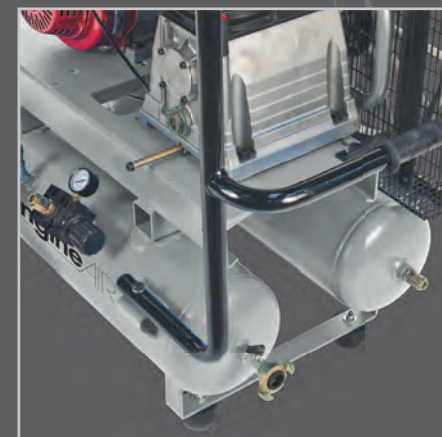

### Twin tank version:

**3 connections for 2 pressures and 1 big flow**  
Inbuilt connection flexibility for different demands

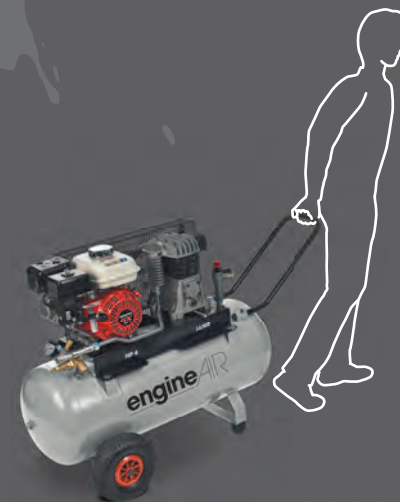

### Ergonomic handle and large pneumatic tyres

For easy movement over difficult terrain

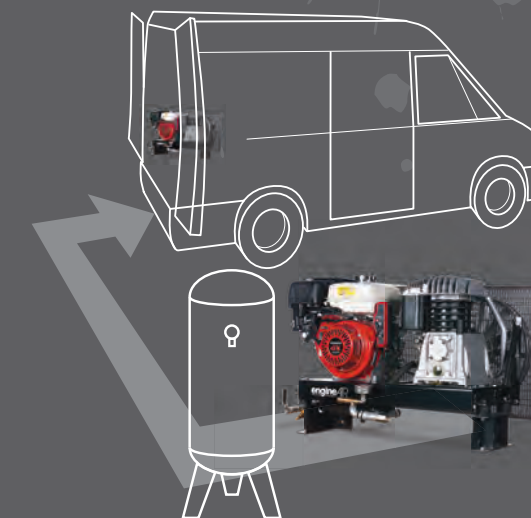

### Easy to install for any kind of application

Pre-installed: just connect to a vessel and you are ready to go



## Diesel Engine

Low fuel consumption

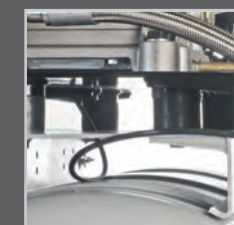

### Anti-vibrating pads

Less vibrations, lower noise level and increased life time of your outside buddy

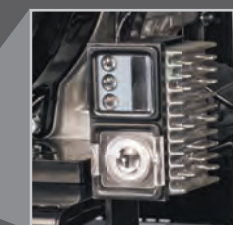

### Easy maintenance

Led control panel, oil pressure and battery recharge indicator

## Bi-Energy

*The two-in-one solution with small footprint*

One powerful motor, supplying both air and energy. Generator with electricity plug at 230 volt

2.2 kva (max)

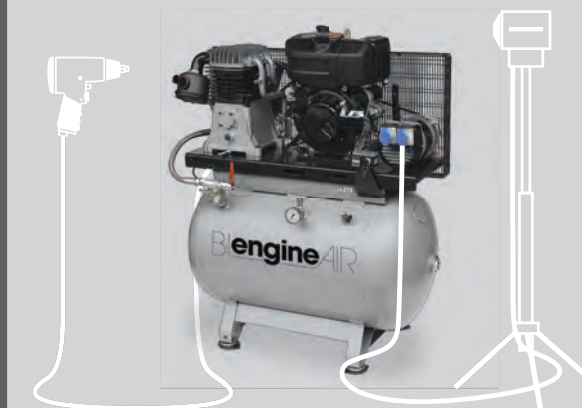

**Blengine**AIR